

# INSTRUCTIONS FOR JELD-WEN 5 DOOR PULL OUT DISPLAY

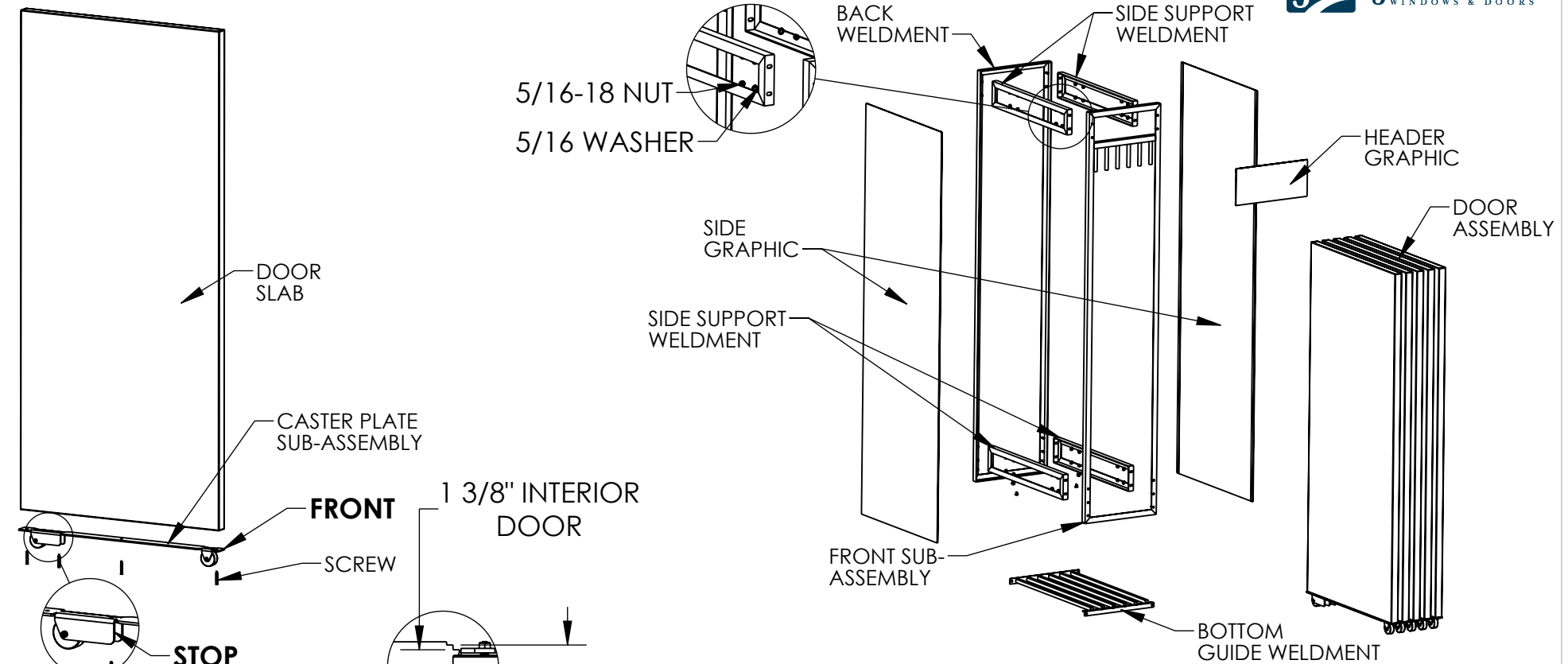

**STEP 1**  
 CENTER CASTER PLATE SUB-ASSEMBLY ON BOTTOM OF 36" DOOR SLAB SIDE TO SIDE USING THE NOTCHED GUIDES IN THE PLATE, FRONT EDGE OF DOOR SHOULD BE FLUSH WITH FRONT EDGE OF CASTER PLATE ASSEMBLY, SECURE IN PLACE USING [5] SUPPLIED #10 X 2" SELF DRILLING SCREWS. REPEAT STEP TO INSTALL REMAINING CASTER PLATE SUB-ASSEMBLIES. NOTE...WHEN USING 30" WIDE DOOR PLACE DOOR SLAB FLUSH WITH FRONT EDGE OF CASTER PLATE SUB-ASSEMBLY AND ALIGN USING THE NOTCHED GUIDES. THEN USE 3 SCREWS TO SECURE. STOP ON CASTER PLATE SHOULD BE TOWARDS THE BACK, SEE DETAIL VIEW ABOVE.

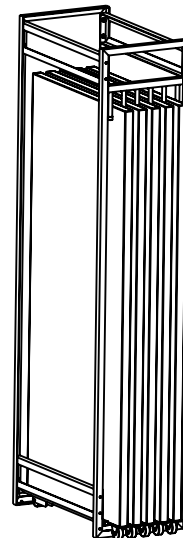

**ASSEMBLED VIEW**

**STEP 2**  
 ATTACH FRONT SUB-ASSEMBLY AND BACK WELDMENT USING [4] SIDE SUPPORT WELDMENTS, [1] BOTTOM GUIDE WELDMENT, [20] 5/16" WASHERS, AND [20] 5/16-18 LOCK NUTS. (4 TREE CLIPS INCLUDED FOR OPTIONAL SKID TABS)

**STEP 3**  
 ATTACH SIDE GRAPHICS AND HEADER GRAPHIC TO METAL FRAME USING PRE APPLIED DOUBLE SIDED TAPE.

**STEP 4**  
 INSTALL DOOR ASSEMBLIES FROM STEP 1 INTO DISPLAY. MAKE SURE STOP ON CASTER PLATE SUB-ASSEMBLIES LOCATED TOWARDS THE BACK SO DOOR ROLLS OUT THE PROPER DISTANCE.

**ASSEMBLY IS COMPLETE!**