

PACKLIST/INSTRUCTIONS FOR KD ENTRY POINT DISPLAY

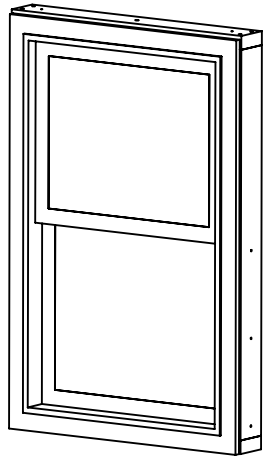

BUCK ASSEMBLY WITH WINDOW AND TRIM QTY: 1



GRAPHIC PANEL W/TAPE APPLIED TO BACK QTY: 2



GRAPHIC STRAP QTY: 2

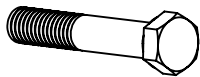

3/8-16 X 2-1/2\"/>



3/8\"/>



1/4\"/>

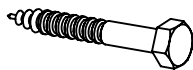

1/4\"/>



#8 X 3/4\"/>

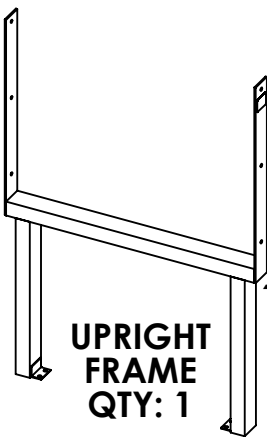

UPRIGHT FRAME QTY: 1

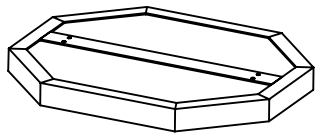

BASE ASSEMBLY QTY: 1

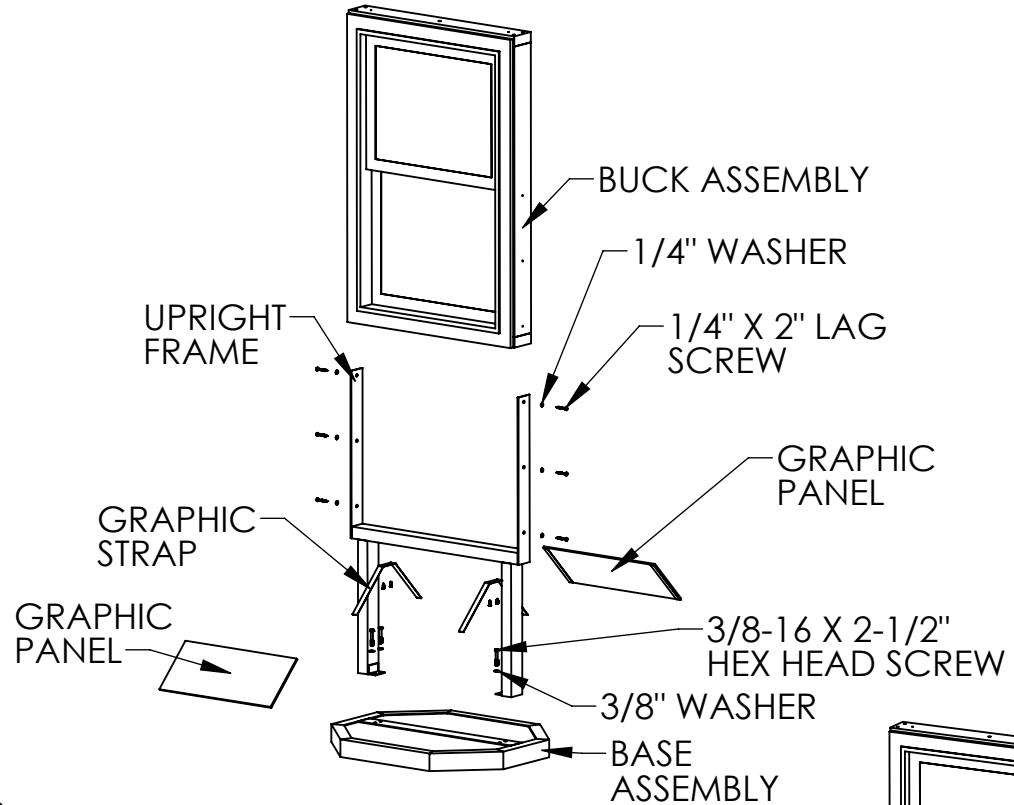

STEP 1:

ATTACH UPRIGHT FRAME TO TOP OF BASE ASSEMBLY USING [4] 3/8-16 X 2\"/>

STEP 2:

ATTACH [2] GRAPHIC STRAPS TO BOTTOM SIDE OF TUBE ON UP UPRIGHT FRAME USING [4] #8 X 3/4\"/>

STEP 3:

ATTACH BUCK ASSEMBLY TO UPRIGHT FRAME USING [6] 1/4\"/>

STEP 4:

ATTACH GRAPHIC PANELS TO GRAPHIC STRAPS WITH PREAPPLIED TAPE ON BACKSIDE OF PANELS

NOTE: GRAPHICS TAPED TO BOTTOM OF WINDOW BUCK BOX WRAPPED UNDER "GRAPHICS ENCLOSED" SHEETING FOAM.

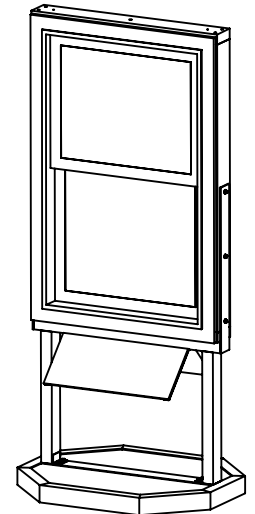

ASSEMBLED VIEW

MISC:

[1] PACKLIST/INSTRUCTIONS

REV. 1
4/5/17



JELD-WEN
WINDOWS & DOORS